

Product Description



MAB 102B Separation System

Application

Purification of mineral oils (fuel, lubricating, turbine) used in marine and power installations.

Concept

The MAB 102B separation system comprises:

- a MAB 102B separator
- a built-on double pump
- a DC/AC inverter if 24V DC input voltage supply
- ancillary components.

The separation system can be supplied with a water seal alarm comprising STAWA-40 monitoring unit, pressure switch, gauge, solenoid valve and regulating valve.

Input voltage supply can be either of AC or 24V DC.

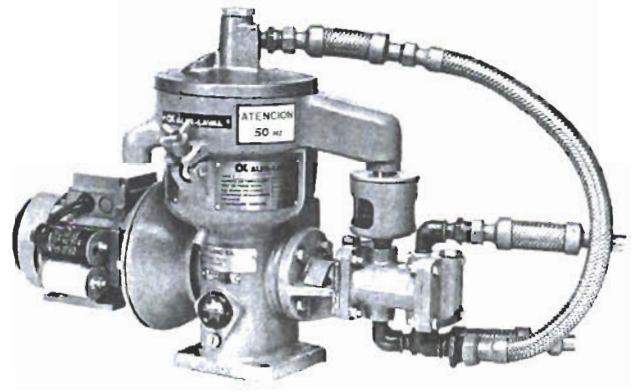

Fig. 1 MAB 102B Separation system

Throughput capacity

Oil	l/h
Distillate (1.5—5.5 cSt/40° C)	600
Marine diesel oil, MDO (13 cSt/40° C)	450
Lube oil (LO) trunk detergent	150
Lube oil (LO) steam turbine (32—46 cSt/40° C)	500

Working principle

Separation takes place in a solid-wall bowl (Fig. 2) arranged for purification. The contaminated oil is fed into the centre of the bowl where it is separated by centrifugal force into its various phases, the heaviest phase (the solid particles) being deposited at the periphery of the bowl.

A purifier is used for separating oils containing solids and an appreciable amount of water, the oil and water being discharged continuously through two separate outlets at the top.

The accumulation of sludge is removed from the bowl periodically by hand.

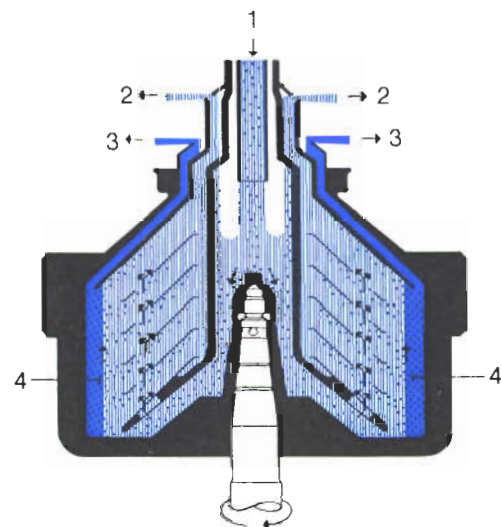

Fig. 2 MAB 102B purifier

1. Feed consisting of oil, water, and solid particles
2. Clean oil
3. Water
4. Solid particles

Technical data in brief

Pump capacity:	560 l/h
Suction head of supply pump:	4 m water column.
Delivery head of discharge pump:	15 m water column.
Input voltage supply:	24V DC 220 V, 380 V, 415/440 V AC (50/60 Hz)
Power consumption:	0.3 kW — 50 Hz 0.36 kW — 60 Hz

Dimensions

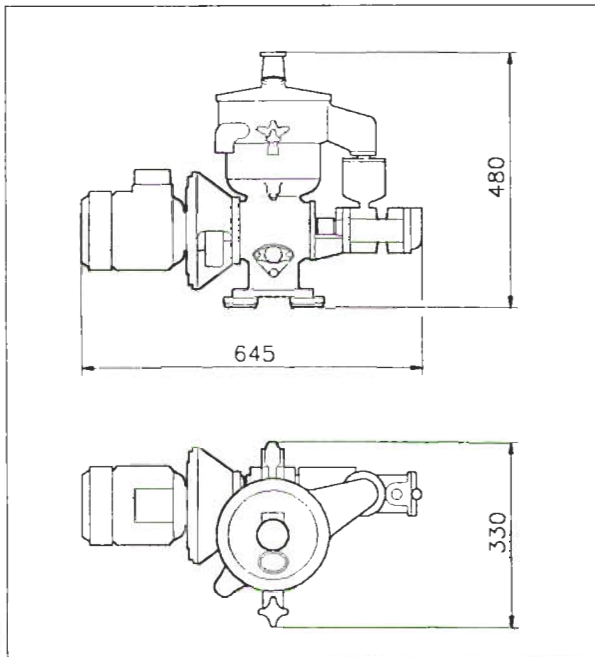

Fig.3 Dimension drawing

Technical documentation

Complete information and documentation is included in the Instruction Book (IB) accompanying the MAB 102B Separation system.

After-sales support

Spare parts are available from Alfa-Laval Marine Service Centers worldwide.



140 PD3-1E
9006

Published by: Alfa-Laval Separation AB, Department SLP, Tumba, Sweden