

1.5-1 Flow Chart Separation System PU Single Module

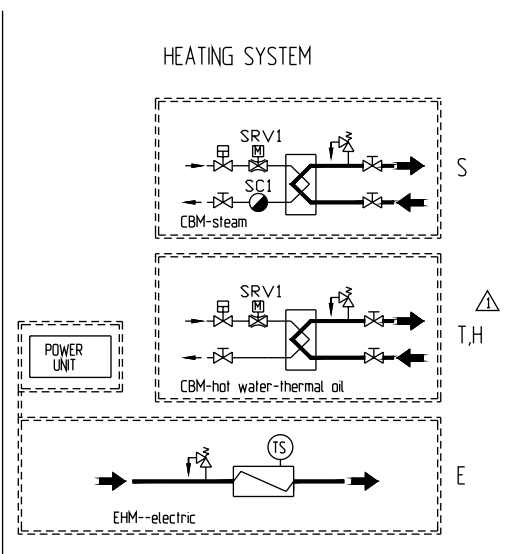

- 201 Oil inlet
- 206 Water for water seal and displacement
- 209 Oil recirculation to tank
- 220 Clean oil outlet
- 222 Sludge discharge outlet
- 371 Operating water
- 372 Opening water
- 376 Closing water
- 463 Drain
- 501 Operating air
- 540 Ventilation
- ===== Optional Alfa Laval delivery
- Block mounted
- Separation Unit

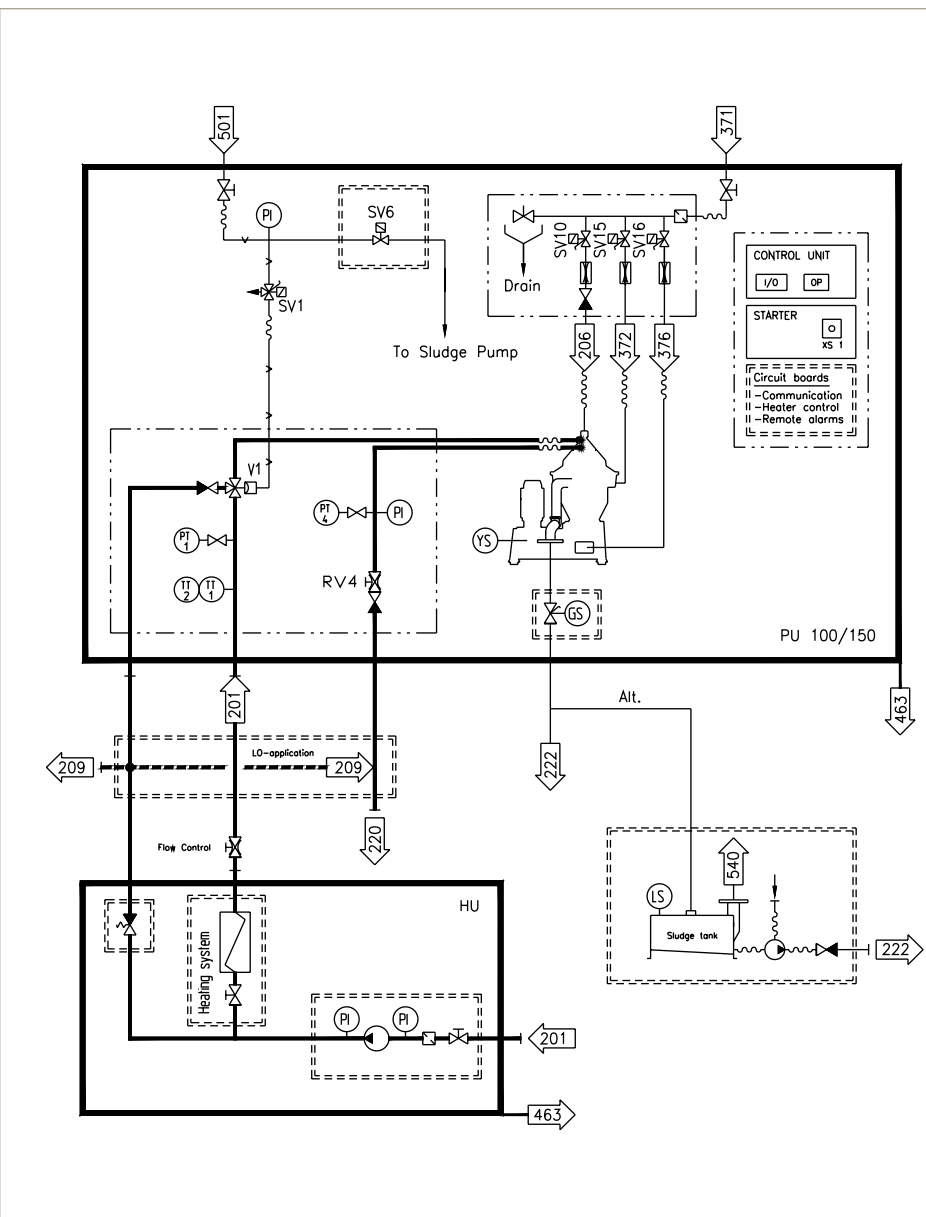

Ref: 53550931 Rev. 1

Marine & Diesel Product Catalogue  
 Illustrations, indications of material, dimensions and weights etc herein, do not constitute any commitment on our part.  
 We reserve the right to change such specifications when necessary.